



Infračervený skupinový splachovač pisoárů s elektronikou ALS, matný, 24 V DC
Infra-red flushing unit for a group of urinals, brushed, 24 V DC

(CS) Návod na použití	(RU) Инструкция по эксплуатации	(RO) Instrucțiuni de utilizare	(NL) Gebruiksaanwijzing
(SK) Návod na použitie	(DE) Gebrauchsanleitung	(ES) Instrucciones de uso	(LT) Naudojimosi instrukcija
(EN) Instructions for use	(PL) Instrukcja użytkownika	(FR) Mode d'emploi	(HU) Használati útmutató

(CS) STANDARDNÍ funkce	(RU) СТАНДАРТНАЯ программа	(RO) Funcționare în regim STANDARD	(NL) Standaard functies
(SK) Funkcia	(DE) Funktion	(ES) Función estándar	(LT) STANDARTINĖ programa
(EN) Function	(PL) Funkcja	(FR) Fonction	(HU) Működés

1.

2.

3.

4.

velikost oka sita $\le 90 \mu\text{m}$
sieve dimension $\le 90 \mu\text{m}$

0,1 - 0,6 MPa
pressure

H₂O

(CS) Vlastnosti	(RU) Технические характеристики	(RO) Proprietăți	(NL) Eigenschappen
(SK) Vlastnosti	(DE) Eigenschaften	(ES) Características	(LT) Techninės charakteristikos
(EN) Properties	(PL) Właściwości	(FR) Caractéristiques	(HU) Tulajdonságok

1.

0,5 - 15,5 sec

FACTORY SETTINGS 3 s.

SLD 03: 0,5 - 15,5 s.

2.

ON/OFF
STISKNI
PRESS

SLD 03: ON / OFF



3.

STOP

INTERVAL HYGIENICKÉHO
PROPLACHU
HYGIENIC FLUSH INTERVAL

FACTORY SETTINGS 24 h.

SLD 03: OFF / 6 / 8 / 12 / 24 / 48 / 72 / 168 h.

 Pouze pro splachovače označené symbolem  Only for flushing unit marked with the symbol

<p>1.</p> <p>ECO 1</p> <p>ECO 2</p> <p>OFF</p> <p>STISKNI PRESS</p> <p>FACTORY SETTINGS OFF</p> <p>Eco 1, Eco 2, OFF</p>	<p>2. ECO 1</p> <p>5 - 1200 s.</p> <p>FACTORY SETTINGS 300 s.</p> <p>5 - 1200 s.</p>	<p>3. ECO 2</p> <p>0,5 - 15,5 s.</p> <p>FACTORY SETTINGS 1 s.</p> <p>0,5 - 15,5</p>	<p>4. ECO 2</p> <p>1x - 30x</p> <p>FACTORY SETTINGS 10x.</p> <p>1 - 30x</p>
--	--	---	---

Eco mode 1

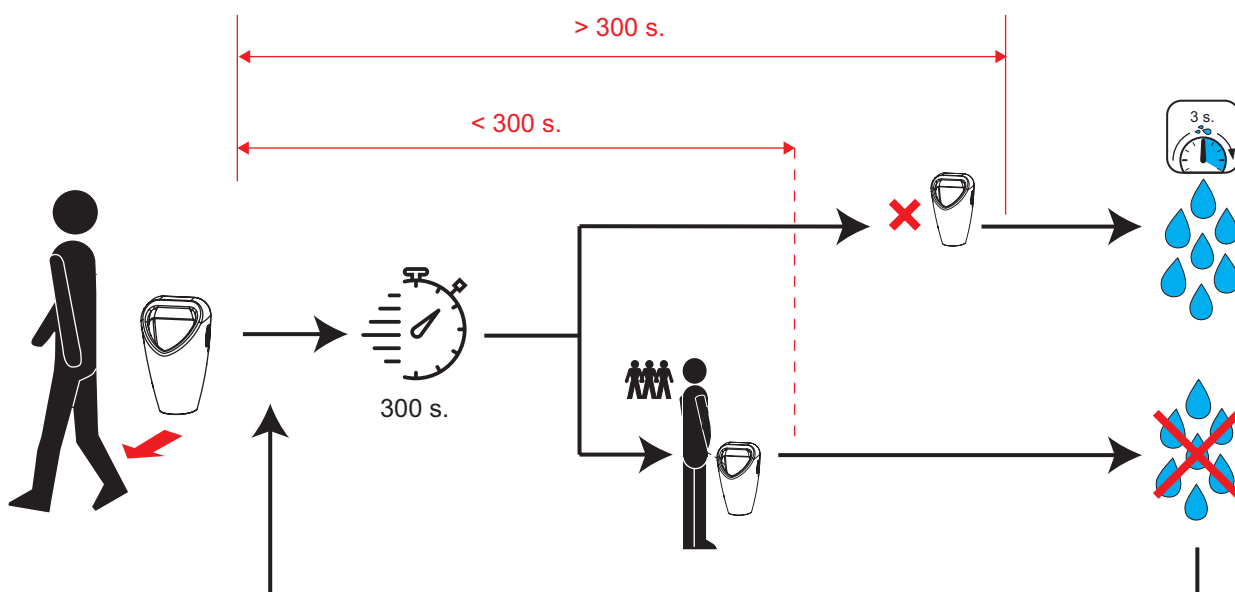

CS

ECO 1
 Funkce „přestávka“: Vhodná pro školy, sportovní stadiony, všude tam, kde se střídají krátké periody s velmi častým používáním a dlouhé periody bez použití. Po prvním použití začne elektronika měřit čas. Pokud v nastaveném čase (ECO mód 1 - Čas - 300s) detekuje další použití, tak nesplachuje. Po vypršení nastaveného času automaticky spláchne s nastavenou dobou splachování (Délka spláchnutí - 3 s). Pokud po tomto spláchnutí není detekováno další použití, tak k žádnému splachování a měření času nedochází. Pokud dojde k dalšímu použití, začne být opět měřen čas (ECO mód 1 - Čas - 300s), po jeho vypršení elektronika opět spláchne. Uživatel podle četnosti a délky přestávek nastaví optimální parametry.

EN

ECO 1
 Function - "Break" Mode: The "Break" function is suitable for environments such as schools, sports stadiums, or any place where short periods of frequent use alternate with long periods of inactivity. After the first use, the electronics initiate time measurement. If another use is detected within the set time (ECO Mode 1 - Time - 300s), the system does not flush. After the expiration of the set time, it automatically flushes with the configured flushing time (Flush Duration - 3 s). If no further use is detected after this flush, no flushing or time measurement occurs. If there is another use, the time measurement starts again (ECO Mode 1 - Time - 300s), and after its expiration, the electronics flush again. The user can adjust optimal parameters based on the frequency and duration of breaks.

Eco mode 2

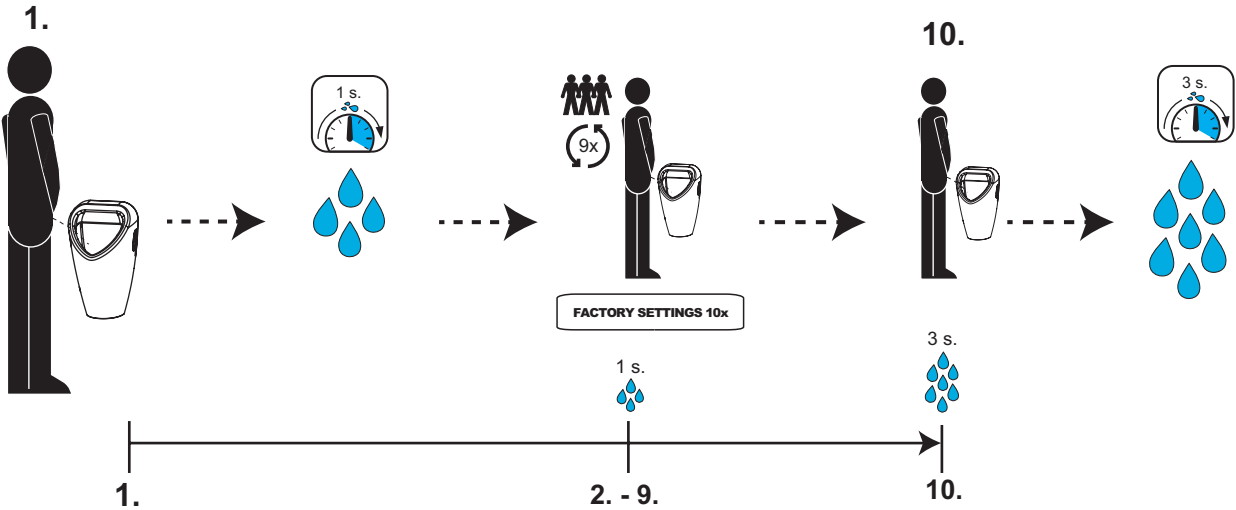

CS

ECO 2
 Funkce „kancelář“: Vhodná tam, kde je pisoár v průběhu dne používán v relativně krátkých, nepravidelných intervalech. Pisoár splachuje po každém použití, ale ne vždy stejným objemem vody. V nastaveném (nastavitelném) poměru (ECO mód 2 počet použití—10) se střídají „malá“ spláchnutí (ECO mód 2 délka spláchnutí) —1s, která slouží pouze k oplachu pisoáru, aby se předešlo zápachu a „velká“ (Délka spláchnutí — 3 s) spláchnutí, kterými je vyčištěn sifon pisoáru. V tomto továrním nastavení je 48 litrů vody spotřebováno za 118 spláchnutí. Uživatel si podle předpokládané četnosti použití nastaví optimální parametry.

EN

ECO 2
 Function - "Office" Mode: The "Office" function is suitable for environments where a urinal is used in relatively short and irregular intervals throughout the day. The urinal flushes after each use but not always with the same volume of water. In the set (adjustable) ratio (ECO Mode 2 usage count - 10), "small" flushes (ECO Mode 2 flush duration - 1s) alternate, serving only to rinse the urinal and prevent odors, with "large" flushes (Flush Duration - 3 s) that clean the urinal trap. In this factory setting, 48 liters of water are consumed for 118 flushes. The user can adjust optimal parameters based on the anticipated frequency of use.

(CS) Montážní návod (RU) Инструкция по монтажу (RO) Instrucțiuni de montaj (NL) Montage instructie
 (SK) Montážny návod (DE) Montageanleitung (ES) Manual de instrucciones (LT) Montavimo instrukcija
 (EN) Mounting instructions (PL) Instrukcja montażu (FR) Notice de montage (HU) Szerelési útmutató

(CS) Specifikace dodávky (RU) Спецификация поставки (RO) Componente livrate (NL) Leveringsomvang
 (SK) Špecifikácia dodávky (DE) Lieferumfang (ES) Especificación de suministro (LT) Tiekimo specifikacija
 (EN) Supplied equipment (PL) Specyfikacja dostawy (FR) Equipements fournies (HU) Tartozékok

SLP 05KX - obj. č. (Code Nr.) - 01055

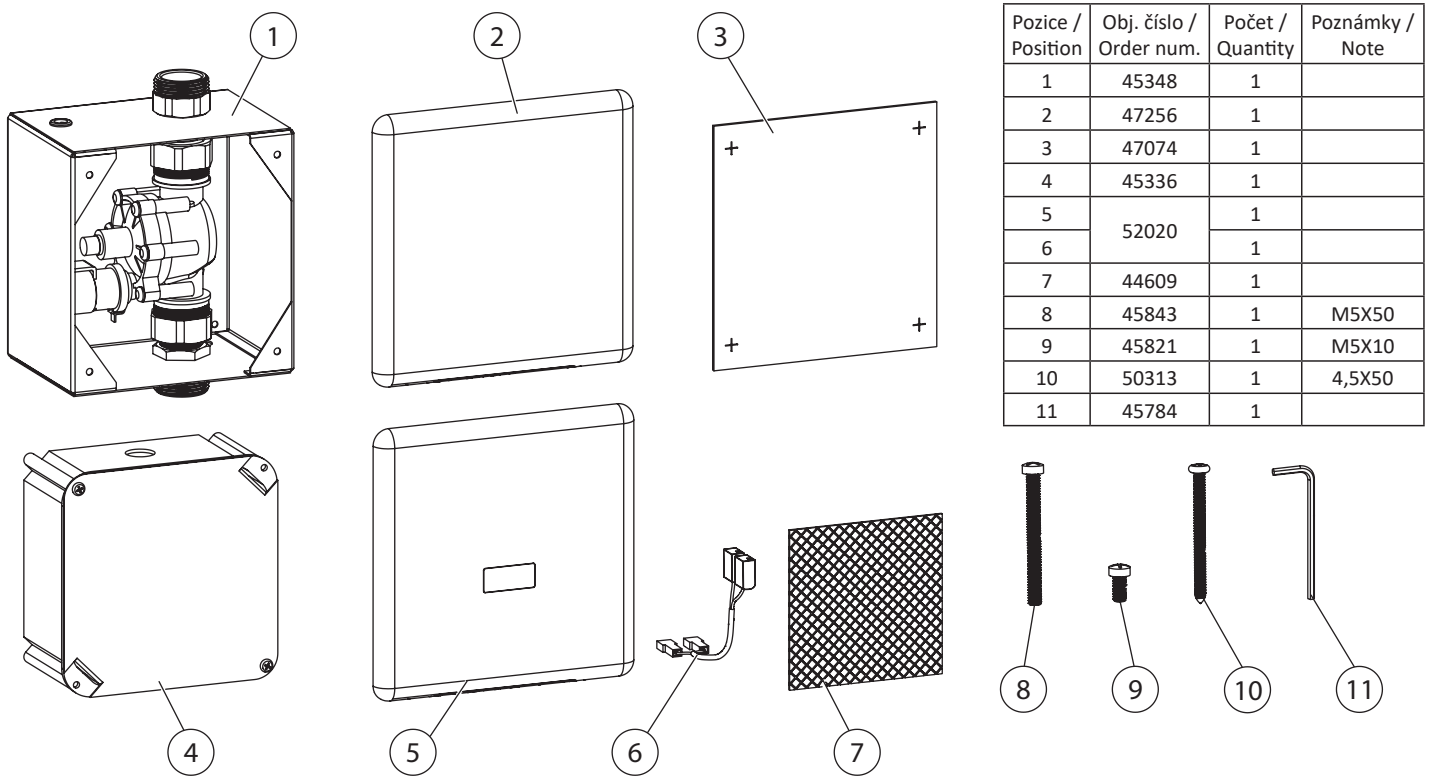

CS Stavební připravenost
SK Stavebná príprava
EN Technical Drawing

RU Технический рисунок
DE Technische Zeichnung
PL Zestawienie budowlane

RO Schița Tehnică
ES Dibujo técnico
FR Dessin technique

NL Technische Tekening
LT Techninis brėžinys
HU Műszaki rajz

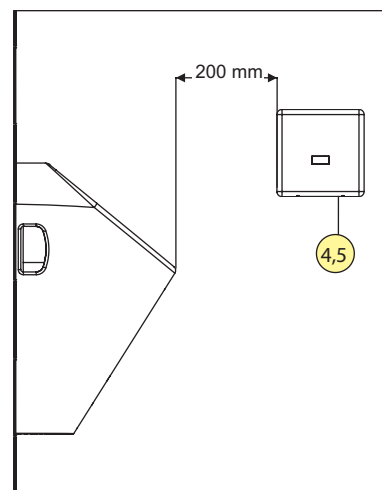
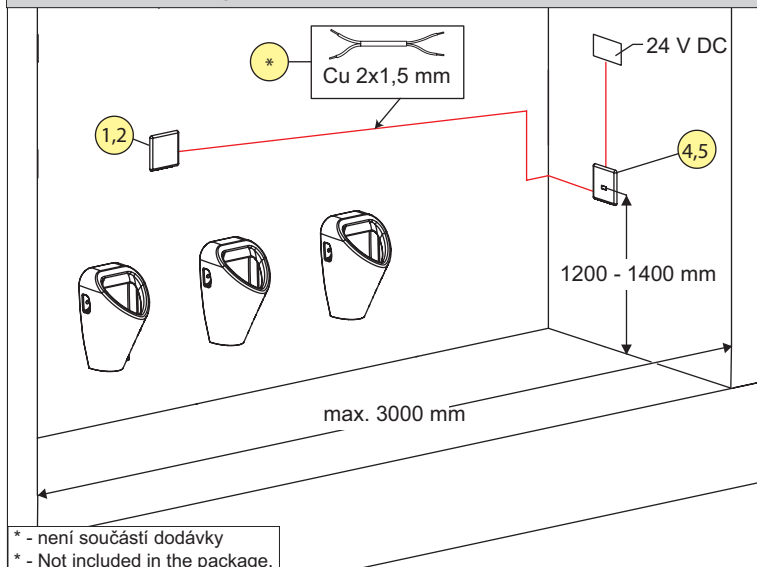

* - není součástí dodávky
* - Not included in the package.

Schéma zapojení vody / Water circuit diagram

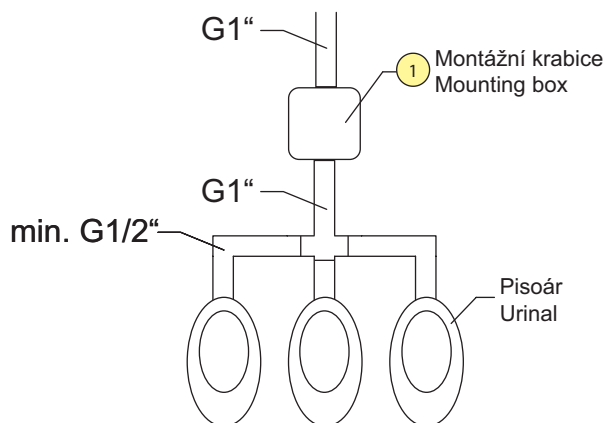

CS Instalace
SK Inštalácia
EN Installation

RU Схема включения и монтажа
DE Installation
PL Instalacja

RO Instalare
ES Instalación
FR Installation

NL Installatie
LT Montavimo ir įjungimo schema
HU Beüzemelés



CS – Před instalací je nezbytné důkladně se seznámit s přiloženými Bezpečnostními pokyny.

EN – Before installation, it is essential to thoroughly familiarize yourself with the attached Safety Instructions.

SK – Pred inštaláciou je nevyhnutné dôkladne sa oboznámiť s priloženými Bezpečnostnými pokynmi.

RU – Перед установкой необходимо внимательно ознакомиться с приложенными инструкциями по безопасности.

DE – Vor der Installation ist es erforderlich, sich gründlich mit den beigefügten Sicherheitsanweisungen vertraut zu machen.

PL – Przed instalacją konieczne jest dokładnie zapoznanie się z dołączonymi instrukcjami bezpieczeństwa.

RO – Înainte de instalare, este necesar să vă familiarizați temeinic cu instrucțiunile de siguranță atașate.

ES – Antes de la instalación, es esencial familiarizarse a fondo con las instrucciones de seguridad adjuntas.

FR – Avant l'installation, il est indispensable de bien prendre connaissance des instructions de sécurité jointes.

NL – Voor de installatie is het noodzakelijk om de bijgevoegde veiligheidsinstructies zorgvuldig door te lezen.

LT – Prieš montavimą būtina atidžiai susipažinti su pridėtomis saugos instrukcijomis.

HU – A telepítés előtt elengedhetetlen, hogy alaposan megismerkedjen a mellékelt biztonsági utasításokkal.

1 Schéma zapojení / Circuit diagram

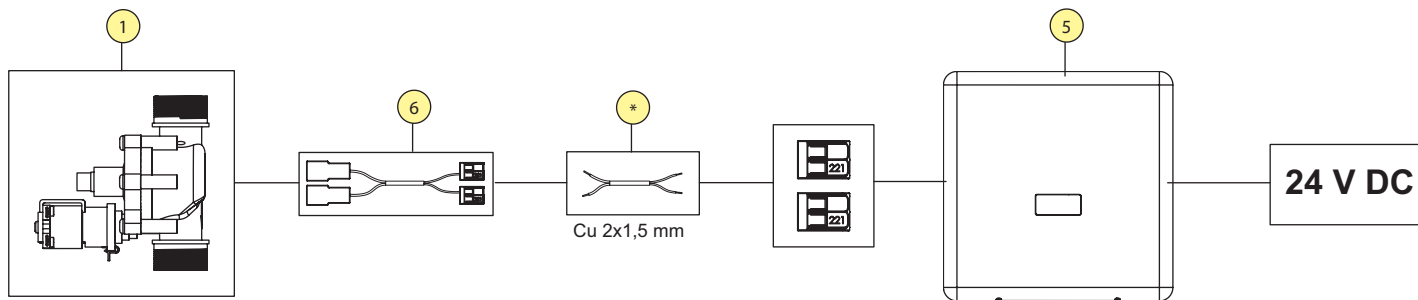

* - není součástí dodávky
 * - Not included in the package.

Instalace montážní krabice (poz. 1.) - elektromagnetický ventil / Installation of the mounting box (item 1) - solenoid valve

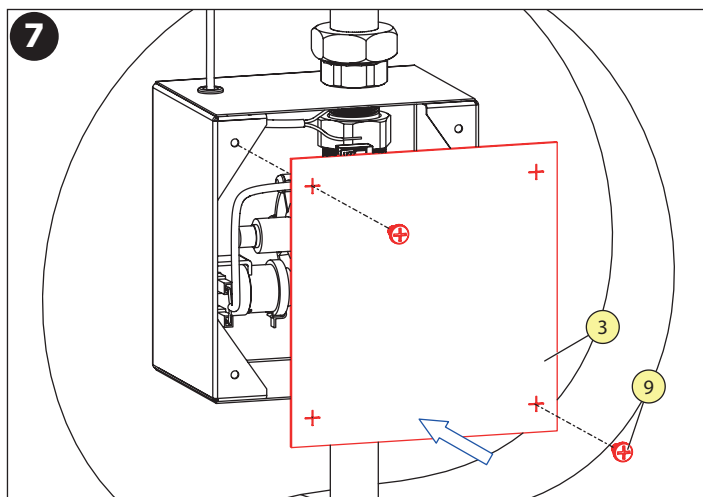
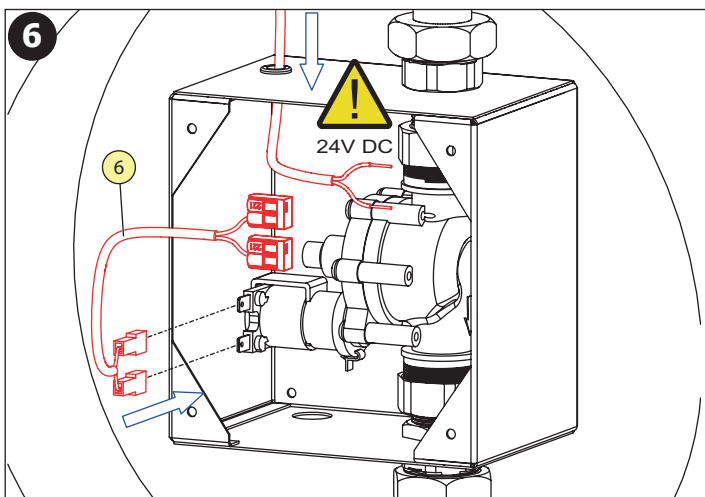
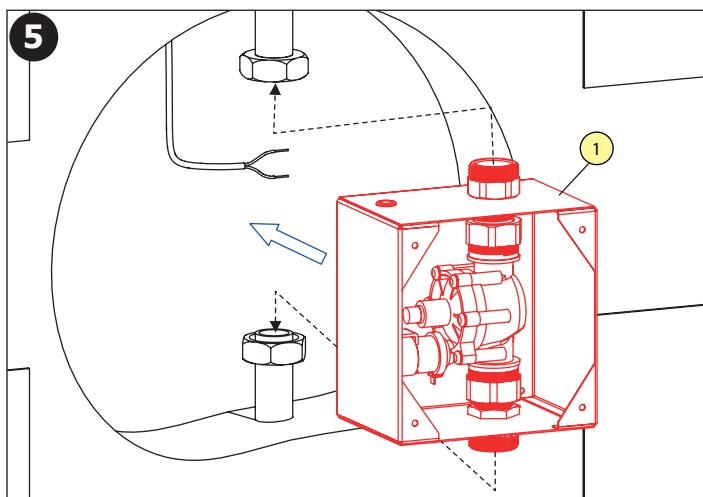
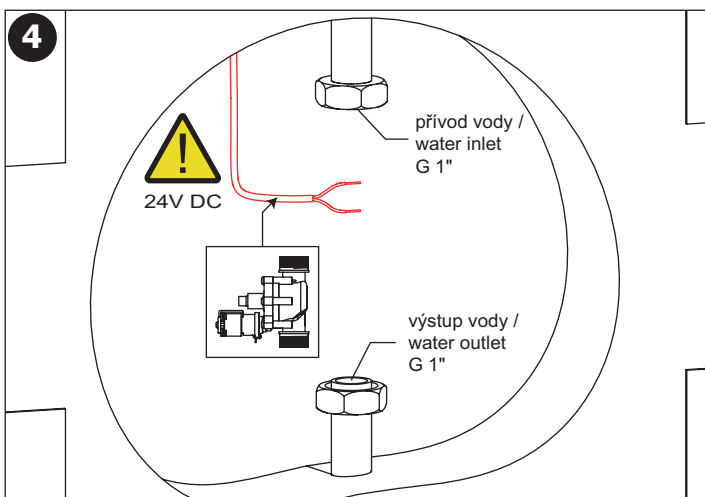
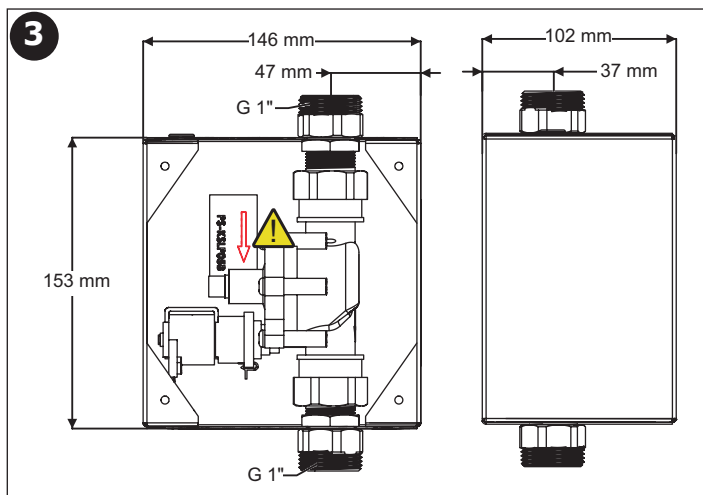
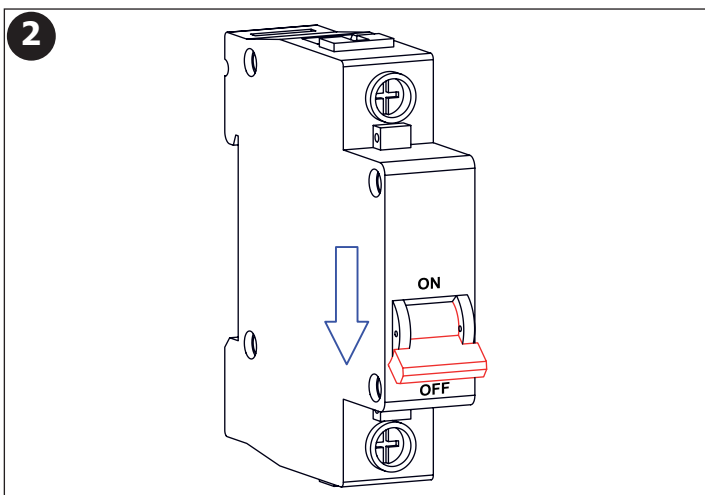

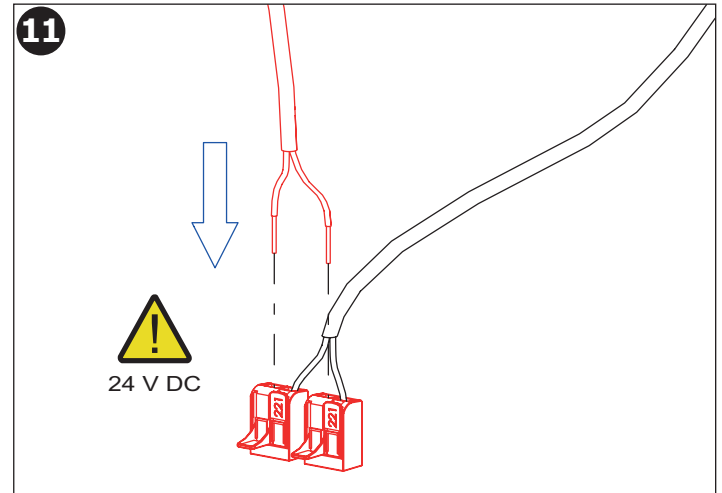
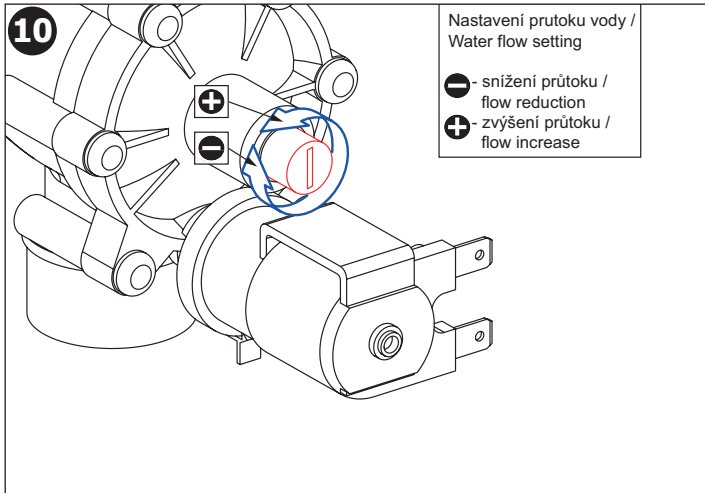
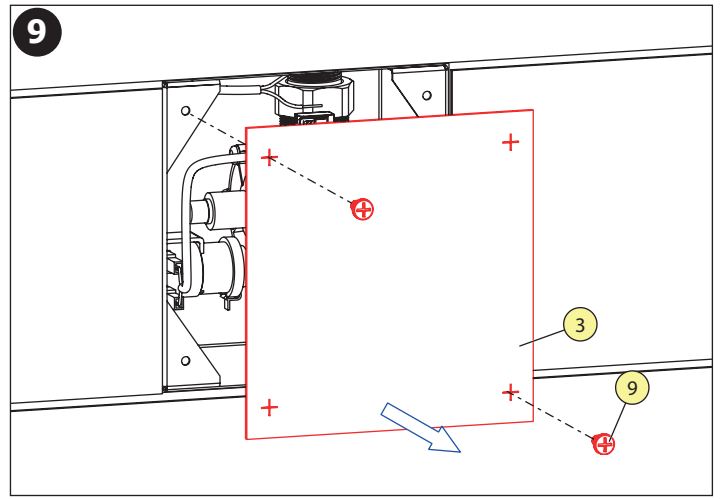
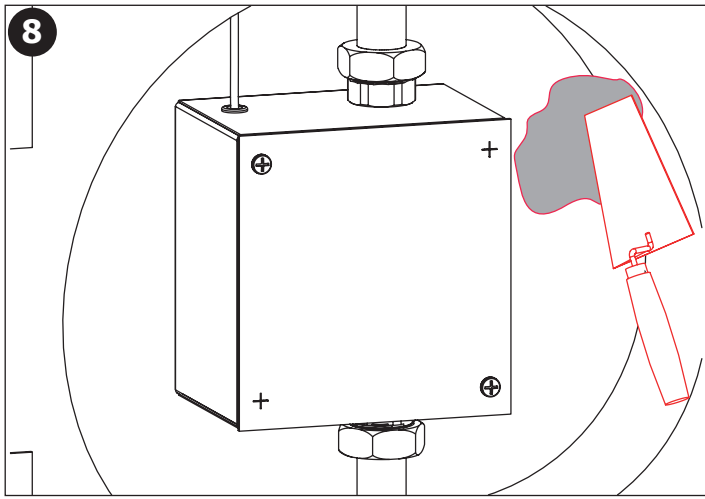

Instalace montážní krabice (poz. 4.) - elektronika / Installation of the mounting box (item 4) - electronic

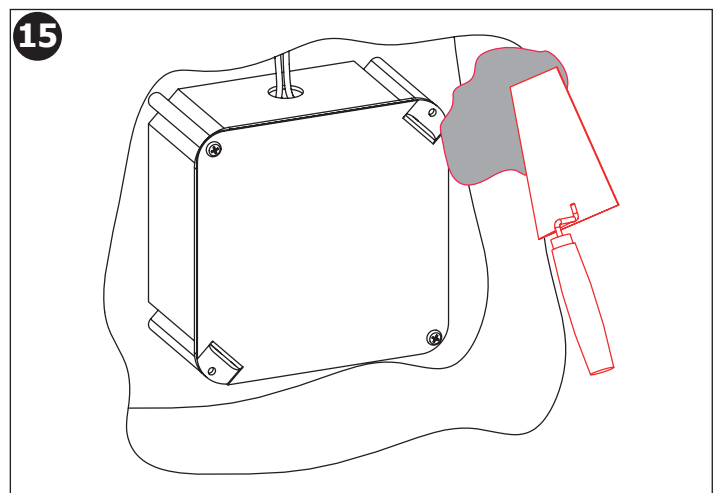
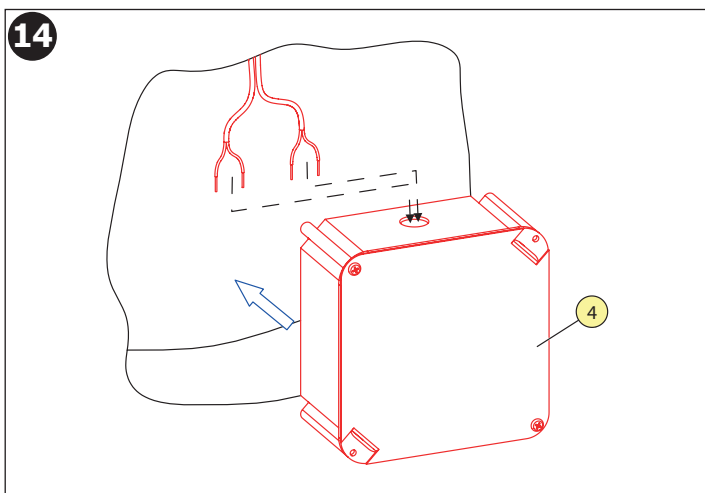
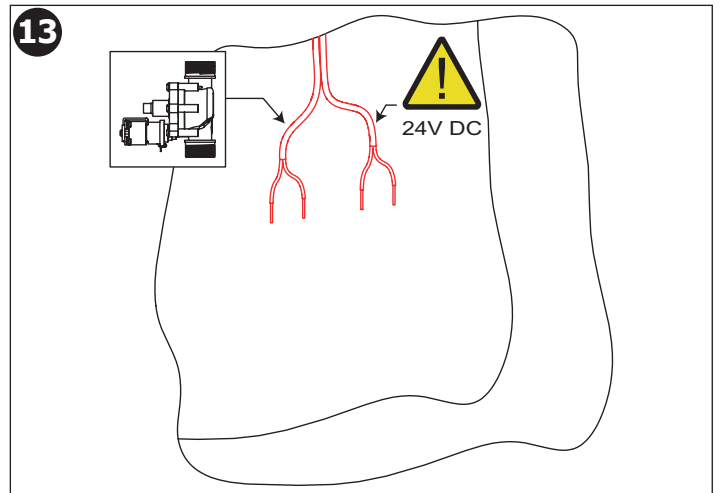
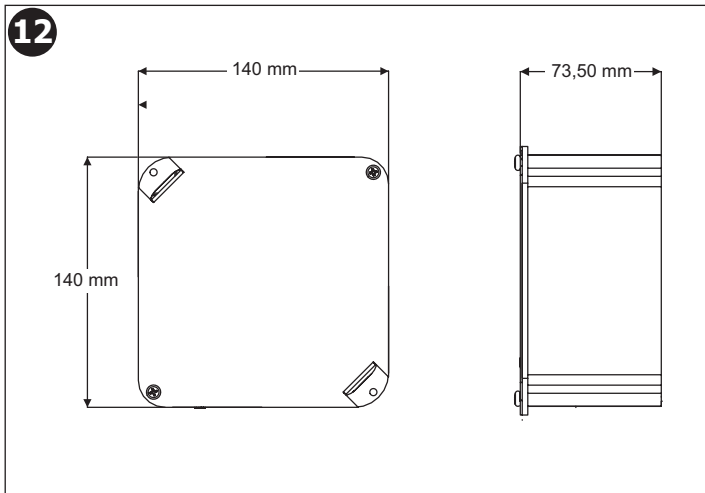

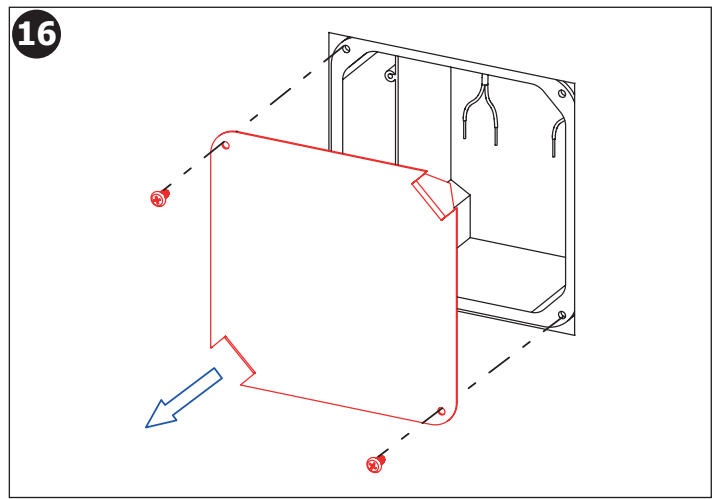
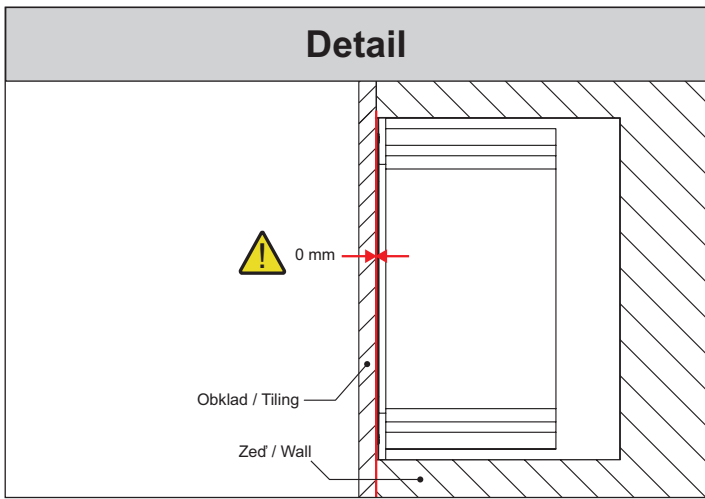

Kompletace - Kryt elektromagnetického ventilu (poz. 2.) / Assembly - Solenoid valve cover (item 2)

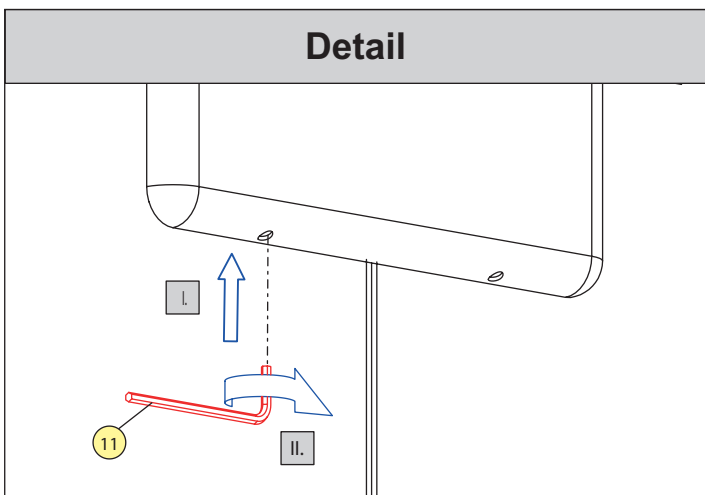
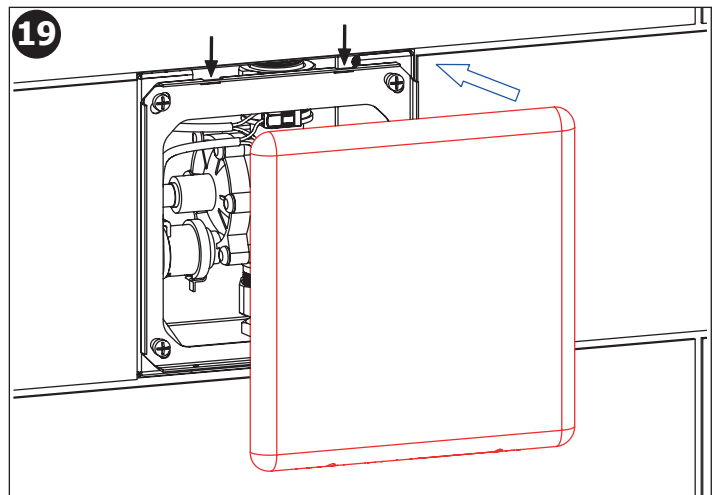
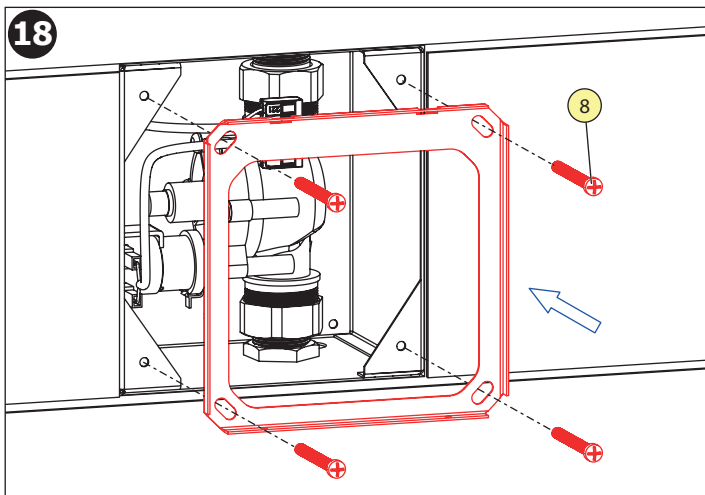
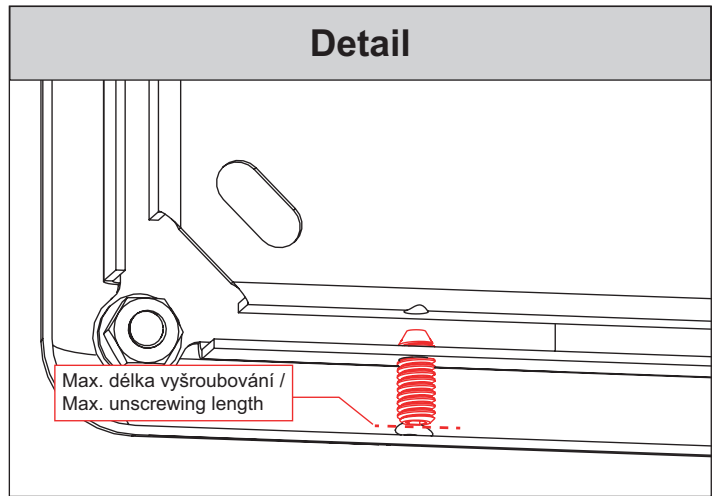
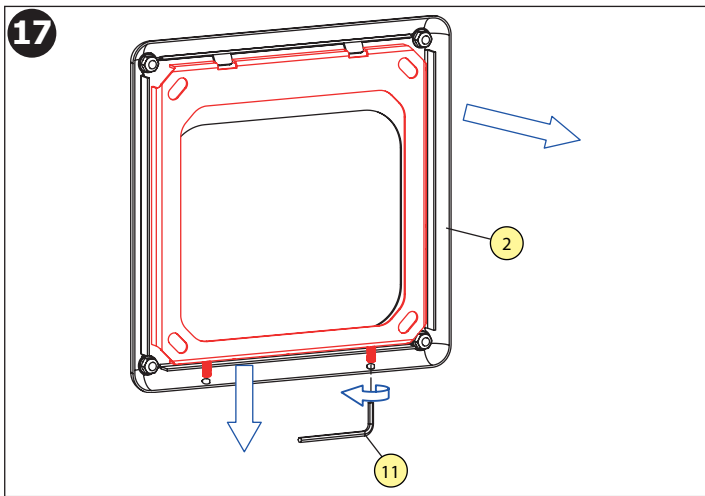

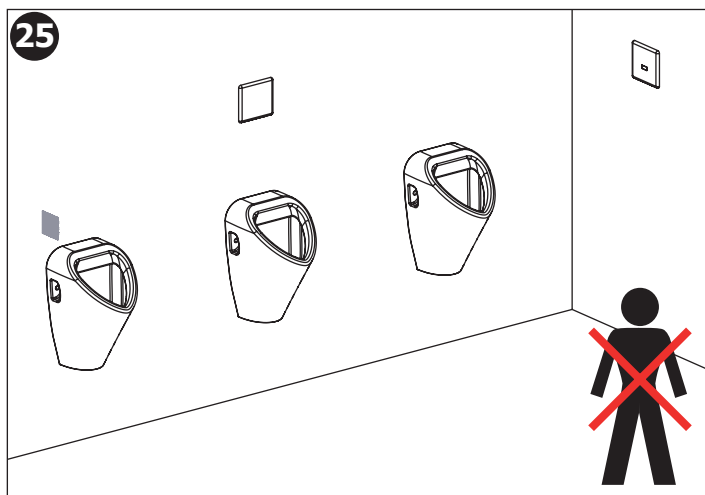
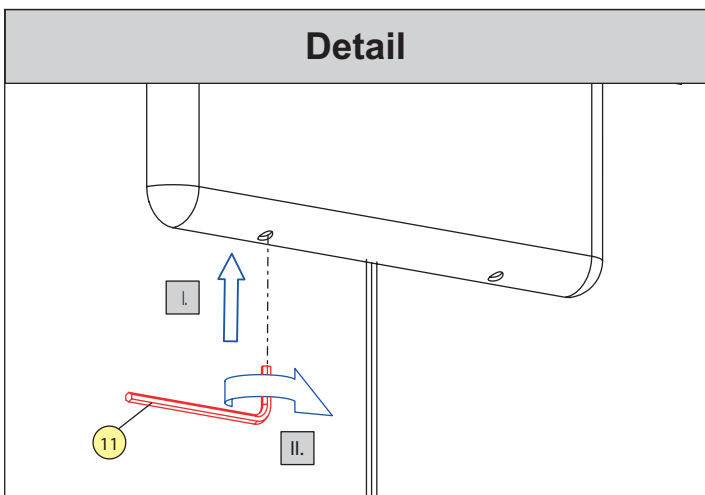
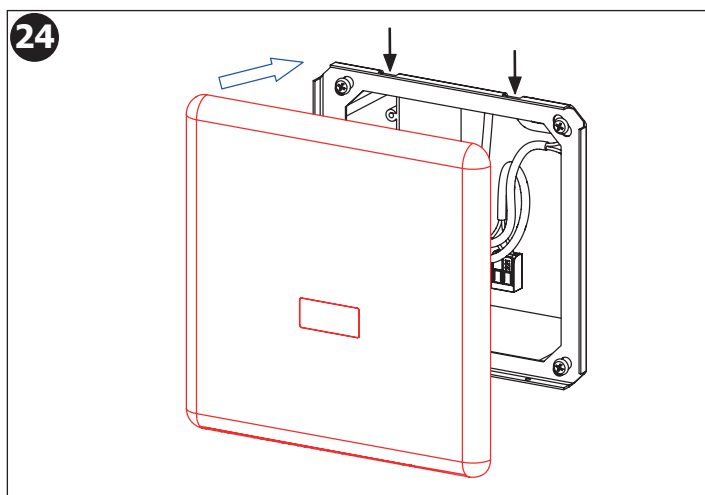
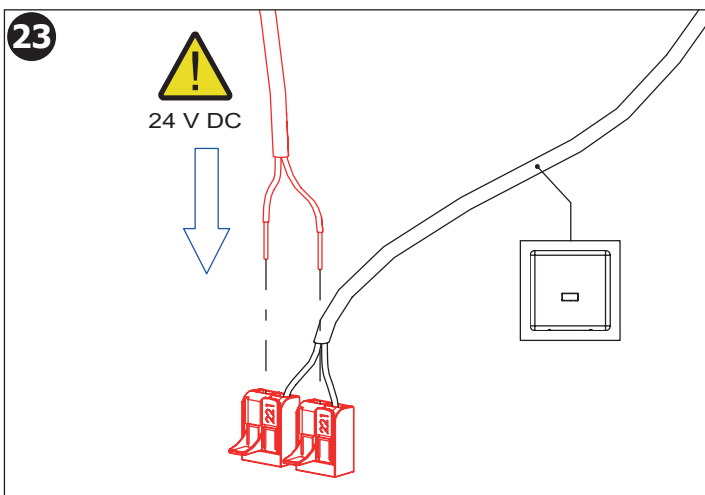
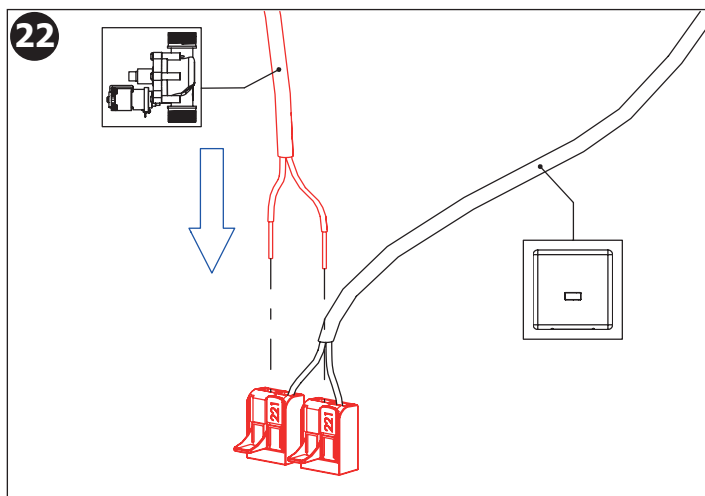
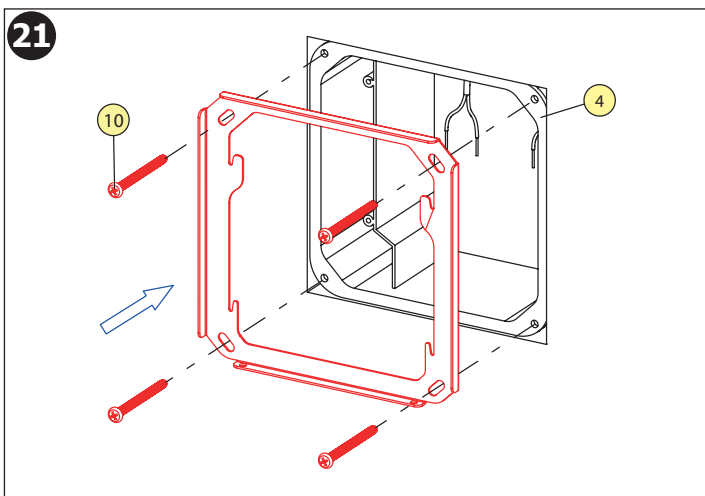
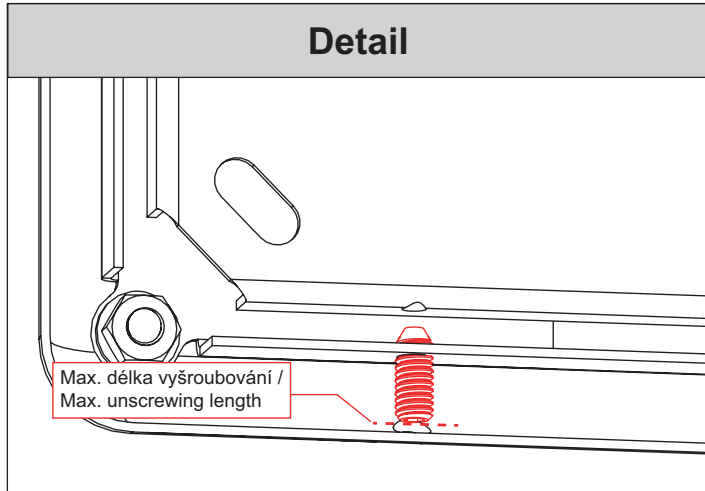
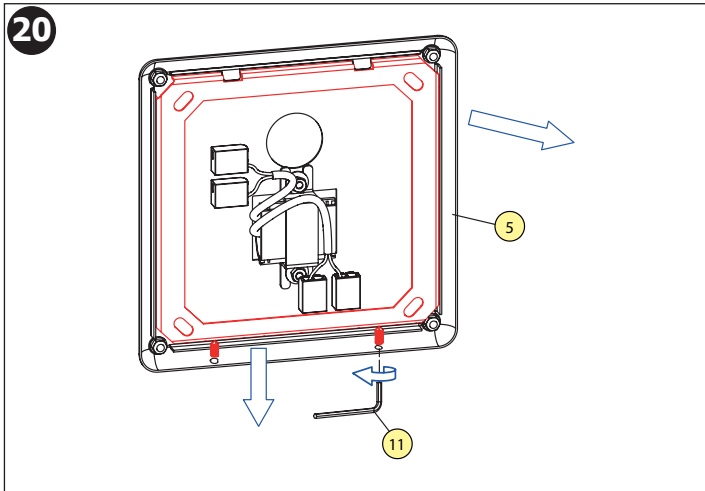

26

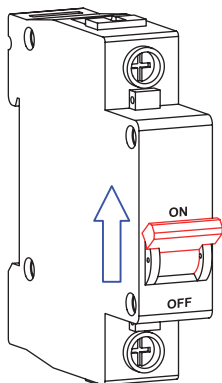

- CS** Pro správnou funkci musí být výrobek trvale pod napětím (nepřipojovat napájecí zdroj za vypínač světelného okruhu)!
- SK** Pre správnu funkciu musí byť výrobok trvale pod napätím (nepripojuvať napájací zdroj za vypínač svetelného okruhu)!
- EN** It is necessary, for the proper function, to keep the unit under constant voltage (don't connect the power supply unit behind the switch into the light circuit)!
- RU** Для бесперебойной работы, изделие должно быть постоянно под напряжением (нельзя подключать источник питания за выключателем световой цепи)!
- DE** Für die richtige Funktion ist es erforderlich, die Einheit unter konstanter Spannung zu halten (den Anschluss des Transformators nicht nach dem Schalter in einem Lichtstromkreis anschliessen)!
- PL** Dla prawidłowego działania urządzenia potrzebne jest stałe zasilanie (nie podłączać zasilania urządzenia pod czujnik ruchu)!
- RO** Pentru o funcționare corespunzătoare unitatea trebuie să fie sub tensiune în mod constant (nu conectați transformatorul după întrerupătorul de la sistemul de iluminat)!
- ES** ¡Para el funcionamiento correcto del producto debe estar sometido a tensión permanente (no conecte la fuente de alimentación del interruptor de trás del circuito de iluminación)!
- FR** Pour le bon fonctionnement il est nécessaire de maintenir l'unité sous tension constante (ne pas connecter l'alimentation derrière un interrupteur)!
- NL** Voor een goede functionaliteit is het noodzakelijk om de unit onder continue spanning te houden (niet de voeding aansluiten achter de knop van het licht-circuit)!
- LT** Kad tinkamai veiktų yra būtina užtikrinti, kad vienetas būtų nuolatiniėje įtampoje (neprijunginėkite maitinimo šaltinio prie šviesos grandinės jungiklio)!
- HU** A megfelelő működéshez elengedhetetlen, hogy az egységet állandó feszültség alatt tartsuk. (a trafót ne kapcsolt áramkörre kössük!)

27

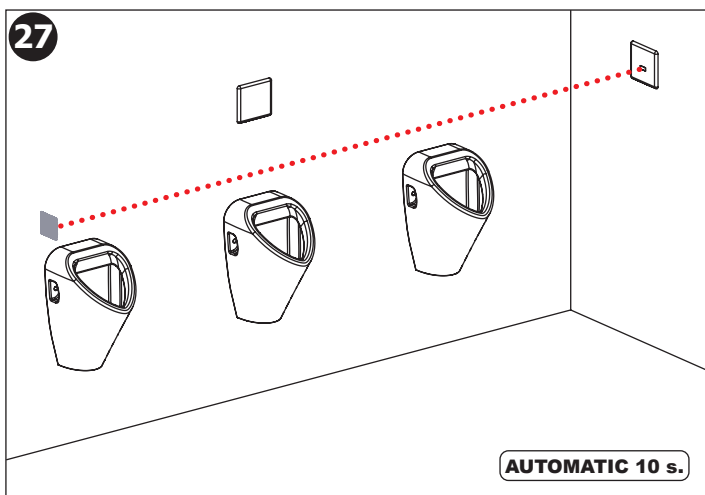

Nastavení / Settings

28

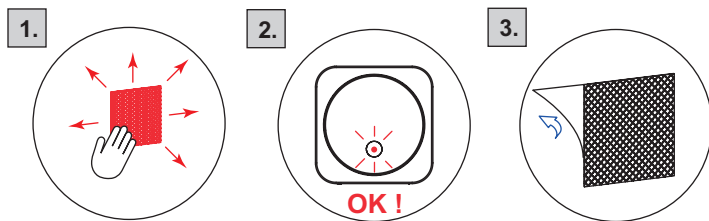

Pohybovat s odrazovou fólií na protilehlé stěně dokud se dioda nerozsvítí!

Move reflexive foil along the opposite wall as long as diode lights up!

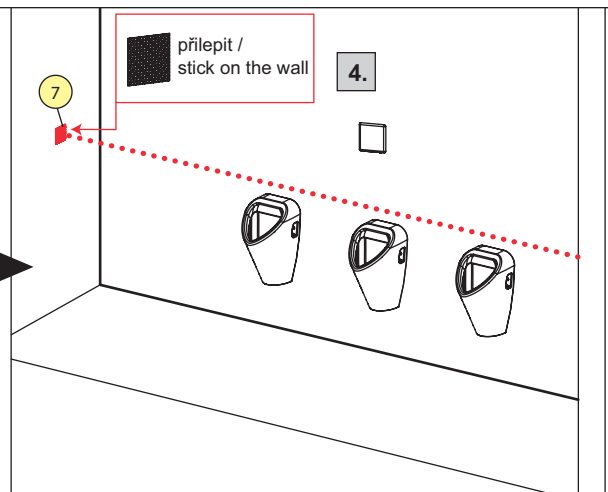

29

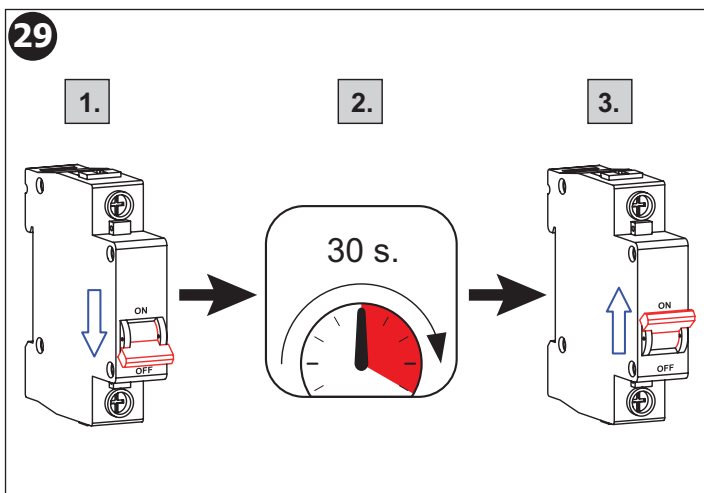

30

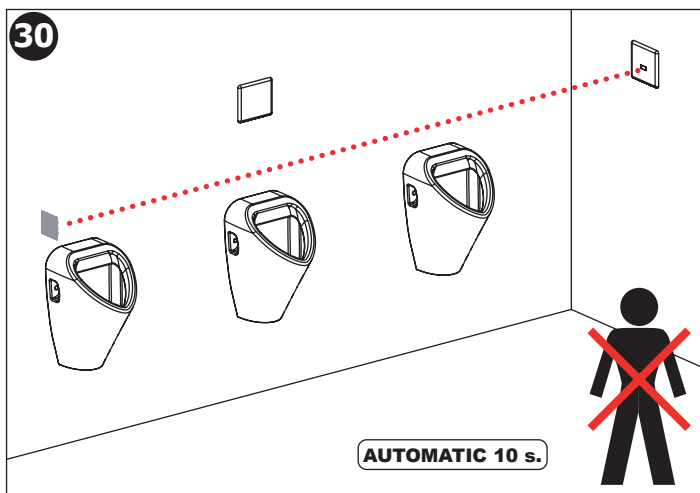

SLA 02	vtoková armatura s těsněním pro přívod vody do pisoárů se zadním vtokem
SLA 30	odrazová fólie
SLD 03	dálkové ovládání pro nastavení parametrů
SLZ 01Y	napájecí zdroj 24 V DC pro max. 5 ks splachovačů
SLZ 01Z	napájecí zdroj 24 V DC pro max. 9 ks splachovačů
SLZ 04Y	napájecí zdroj 24 V DC na DIN lištu, pro max. 5 ks splachovačů
SLZ 04Z	napájecí zdroj 24 V DC na DIN lištu, pro max. 9 ks splachovačů
SLZ 04X	napájecí zdroj 24V DC na DIN lištu, pro max. 15 ks splachovačů
SLZ 06	napájecí zdroj 24 V DC pro max. 1 ks splachovače

SLA 02	inlet fitting with gasket for water supply to urinals with rear inlet
SLA 30	reflective foil
SLD 03	remote control for an adjustment of parameters
SLZ 01Y	power supply 24 V DC for operating of max. 5 pcs. of fl ushing units
SLZ 01Z	power supply 24 V DC for operating of max. 9 pcs. of fl ushing units
SLZ 04Y	power supply 24 V DC on DIN rail, for operating of max. 5 pcs. of fl ushing units
SLZ 04Z	power supply 24 V DC on DIN rail, for operating of max. 9 pcs. of fl ushing units
SLZ 04X	power supply 24 V DC on DIN rail, for operating of max. 15 pcs. of fl ushing units
SLZ 06	power supply 24 V DC for operating of max. 1 pc. of fl ushing unit

CS Návod na údržbu	RU Инструкция по уходу	RO Instrucțiuni de întreținere	NL Onderhoudsinstructies
SK Návod na údržbu	DE Wartungsanleitung	ES Instrucciones de cuidado	LT Priežiūros instrukcija
EN Instructions for maintenance	PL Instrukcja obsługi	FR Instructions pour l'entretien	HU Karbantartási utasítások

Ke stažení zde:



For download:



CS Další informace	RU Дополнительные информации	RO Mai multe informații umeaza	NL Meer informatie
SK Ďalšie informácie	DE Weitere Informationen	ES Más información	LT Daugiau informacijos
EN More information	PL Więcej informacji	FR Plus d'information	HU További Információ

<p><i>K výrobku bylo vydáno příslušné prohlášení o shodě dle platné legislativy. Pro technickou podporu, servisní zásah nebo řešení záved kontaktujte instalační firmu nebo navštivte www.sanela.cz/servis. Je doporučeno provádět pravidelnou údržbu dle Návodu na údržbu: www.sanela.cz/servis-ke-stazeni. Výrobce plní své povinnosti v rámci kolektivního systému zpětného odběru dle platné legislativy. Po vybalení výrobku je nutné s obalem postupovat podle zákona o obalech.</i></p>	CS	<p><i>K výrobku bolo vydané príslušné vyhlásenie o zhode podľa platnej legislatívy. Pre technickú podporu, servisný zásah alebo riešenie porúch kontaktujte inštaláciu firmu alebo navštívte www.sanela.sk/servis. Odporúča sa vykonávať pravidelnú údržbu podľa Návodu na údržbu: www.sanela.sk/servis-k-stiahnutiu. Výrobca plní svoje povinnosti v rámci kolektívneho systému spätného zberu podľa platnej legislatívy. Po vybalení výrobku je potrebné s obalom naložiť v súlade so zákonom o obaloch.</i></p>	SK
---	-----------	---	-----------

<p><i>The relevant Declaration of Conformity has been issued for the product in accordance with applicable legislation. For technical support, service intervention, or fault resolution, please contact the installation company or visit www.sanela.eu/service. It is recommended to perform regular maintenance according to the Maintenance Instructions: www.sanela.eu/service-download. The manufacturer fulfills its obligations within the collective take-back system in accordance with applicable legislation. After unpacking the product, the packaging must be handled in accordance with the Packaging Act.</i></p>	EN	<p><i>На изделие выдана соответствующая декларация о соответствии в соответствии с действующим законодательством. Для получения технической поддержки, вызова сервиса или устранения неисправностей обратиться в монтажную организацию или посетите сайт www.sanela.ru/servis. Рекомендуется регулярно проводить техническое обслуживание согласно Инструкции по обслуживанию: www.sanela.ru/servis-skachat. Производитель выполняет свои обязательства в рамках коллективной системы утилизации в соответствии с действующим законодательством. После распаковки изделия упаковку необходимо утилизировать в соответствии с Законом об упаковке.</i></p>	RU
---	-----------	---	-----------

<p><i>Für das Produkt wurde eine entsprechende Konformitätserklärung gemäß geltender Gesetzgebung ausgestellt. Für technischen Support, Serviceeinsätze oder Störungsbehebungen wenden Sie sich bitte an das Installationsunternehmen oder besuchen Sie www.sanelaeu.de/service. Es wird empfohlen, eine regelmäßige Wartung gemäß der Wartungsanleitung durchzuführen: www.sanelaeu.de/service-herunterladen. Der Hersteller erfüllt seine Pflichten im Rahmen des kollektiven Rücknahmesystems gemäß geltender Gesetzgebung. Nach dem Auspacken des Produkts ist die Verpackung gemäß dem Verpackungsgesetz zu entsorgen.</i></p>	DE	<p><i>Dla produktu została wydana odpowiednia deklaracja zgodności zgodnie z obowiązującymi przepisami. W przypadku potrzeby wsparcia technicznego, interwencji serwisowej lub usunięcia usterek prosimy o kontakt z firmą instalacyjną lub odwiedzenie strony www.sanela.pl/servis. Zaleca się regularne przeprowadzanie konserwacji zgodnie z Instrukcją konserwacji: www.sanela.pl/servis-pobieranie. Producent realizuje swoje obowiązki w ramach systemu zbiorowego odbioru zgodnie z obowiązującymi przepisami. Po rozpakowaniu produktu opakowanie należy zagospodarować zgodnie z ustawą o opakowaniach.</i></p>	PL
---	-----------	---	-----------

<p><i>Pentru produs a fost emisă declarația de conformitate corespunzătoare, în conformitate cu legislația în vigoare. Pentru asistență tehnică, intervenție de service sau remedierea defecțiunilor, contactați firma de instalații sau vizitați www.sanelaeu.ro/service. Se recomandă efectuarea unei întrețineri periodice conform Instrucțiunilor de întreținere: www.sanelaeu.ro/service-download. Producătorul își îndeplinește obligațiile în cadrul sistemului colectiv de preluare, conform legislației în vigoare. După despachetarea produsului, ambalajul trebuie gestionat conform Legii ambalajelor.</i></p>	RO	<p><i>Se ha emitido la correspondiente declaración de conformidad para el producto de acuerdo con la legislación vigente. Para soporte técnico, intervención de servicio o resolución de fallos, contacte con la empresa instaladora o visite www.sanela.eu/service. Se recomienda realizar un mantenimiento regular según las Instrucciones de mantenimiento: www.sanela.eu/service-download. El fabricante cumple con sus obligaciones dentro del sistema colectivo de recogida de residuos conforme a la legislación vigente. Después de desembalar el producto, el embalaje debe gestionarse de acuerdo con la Ley de Envases.</i></p>	ES
---	-----------	---	-----------

<p><i>La déclaration de conformité correspondante a été émise pour le produit conformément à la législation en vigueur. Pour toute assistance technique, intervention de service ou résolution de panne, veuillez contacter l'entreprise d'installation ou consulter le site www.sanela.eu/service. Il est recommandé d'effectuer un entretien régulier selon les Instructions d'entretien : www.sanela.eu/service-download. Le fabricant remplit ses obligations dans le cadre du système collectif de reprise conformément à la législation en vigueur. Après déballage du produit, l'emballage doit être traité conformément à la loi sur les emballages.</i></p>	FR	<p><i>Voor het product is een overeenkomstige conformiteitsverklaring afgegeven volgens de geldende wetgeving. Voor technische ondersteuning, service-interventie of het verhelpen van storingen kunt u contact opnemen met het installatiebedrijf of www.sanela.eu/service. Regelmatig onderhoud volgens de Onderhoudsinstructies wordt aanbevolen: www.sanela.eu/service-download. De fabrikant voldoet aan zijn verplichtingen binnen het collectieve terugnamesysteem volgens de geldende wetgeving. Na het uitpakken van het product moet de verpakking worden afgevoerd volgens de Verpakkingwet.</i></p>	NL
---	-----------	--	-----------

<p><i>Produktui buvo išduotas atitiktis deklaravimas pagal galiojančius teisės aktus. Techninei pagalbai, techninio aptamavimo iškvietimui ar gedimų šalinimui kreipkitės į montavimo įmonę arba apsilankykite www.sanela.eu/service. Rekomenduojama reguliariai atlikti priežiūrą pagal Priežiūros instrukciją: www.sanela.eu/service-download. Gamintojas vykdo savo įsipareigojimus pagal kolektyvinę atliekų surinkimo sistemą, laikydamasis galiojančių teisės aktų. Išpakavus gaminį, pakuotę turi būti tvarkoma pagal Pakuočių įstatymą.</i></p>	LT	<p><i>A termékhez a vonatkozó megfelelőségi nyilatkozat a hatályos jogszabályok szerint kiadásra került. Műszaki támogatás, szervizszolgáltatás vagy hibaelhárítás esetén kérjük, vegye fel a kapcsolatot a telepítő céggel, vagy látogasson el a www.sanela.eu/service. Javasolt a rendszeres karbantartás elvégzése a Karbantartási útmutató szerint: www.sanela.eu/service-download. A gyártó eleget tesz a hatályos jogszabályok szerinti kollektív visszavételi rendszerben vállalt kötelezettségeinek. A termék kicsomagolása után a csomagolással a csomagolásról szóló törvénynek megfelelően kell eljárni.</i></p>	HU
--	-----------	--	-----------